

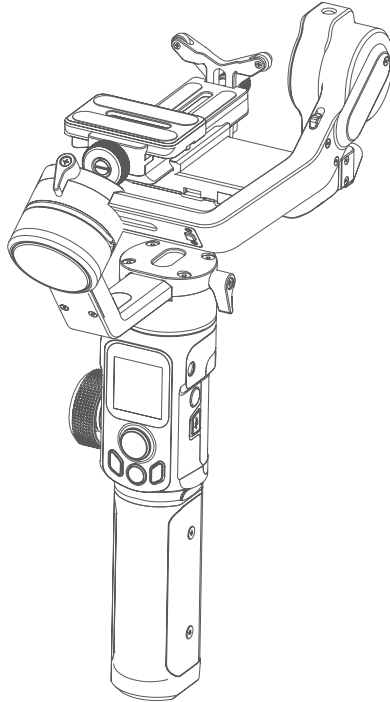

Manfrotto

Imagine More



INSTRUCTIONS
MVG220

Catalogue

1. Product Overview	2
2. Start to use	5
2.1 Charging	5
2.2 Position Lock.....	6
2.3 Camera Installation.....	7
2.4 Gimbal Balancing	8
2.5 Power ON/OFF	10
3. Function operation	10
3.1 Mode/Function Introduction.....	10
3.2 Button Operation.....	12
3.3 USB Port	15
3.4 Touch Screen.....	16
3.5 Modes Setting	18
3.6 Motion-timelapse Mode	20
3.7 Initialization.....	23
3.8 Manual Lock.....	24
4. Manfrotto Gimbal App.....	24
4.1 Download Manfrotto Gimbal App.....	24
4.2 App Connecting	25
4.3 Firmware Upgrade.....	26
5. Accessories	27
5.1 Tripod	27
5.2 Versatile Arm	27
Disclaimer.....	28

Introduction

MVG220 is a professional 3-axis stabilized handheld Gimbal for DSLR and mirrorless camera. It is compatible with popular DSLR and mirrorless cameras on the market. Its detachable versatile arm handle, makes it available to be supporting by single hand and low angle shooting, and is allowed to mounted on tripod and other adaptor.

MVG220 is designed with function button and LCD touch screen, which can switch the Gimbal working mode, control the rotation and the parameters setting by one hand. The camera shutter cable is equipped for controlling the photography, video recording and focus following directly at handle.



Download Manfrotto Gimbal App.







1. Product Overview





Overview

Professional 3-axis gimbal designed for DSLR and mirrorless cameras, designed with function buttons and LCD touch screen.

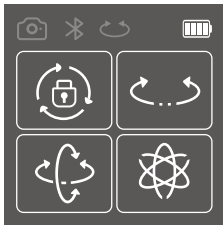
Touch Screen

-  Camera Connection
-  Bluetooth
-  Multifunction Knob Control
-  Battery Level



-  All Lock Mode
-  Pan Mode
-  Follow Mode
-  All Follow Mode

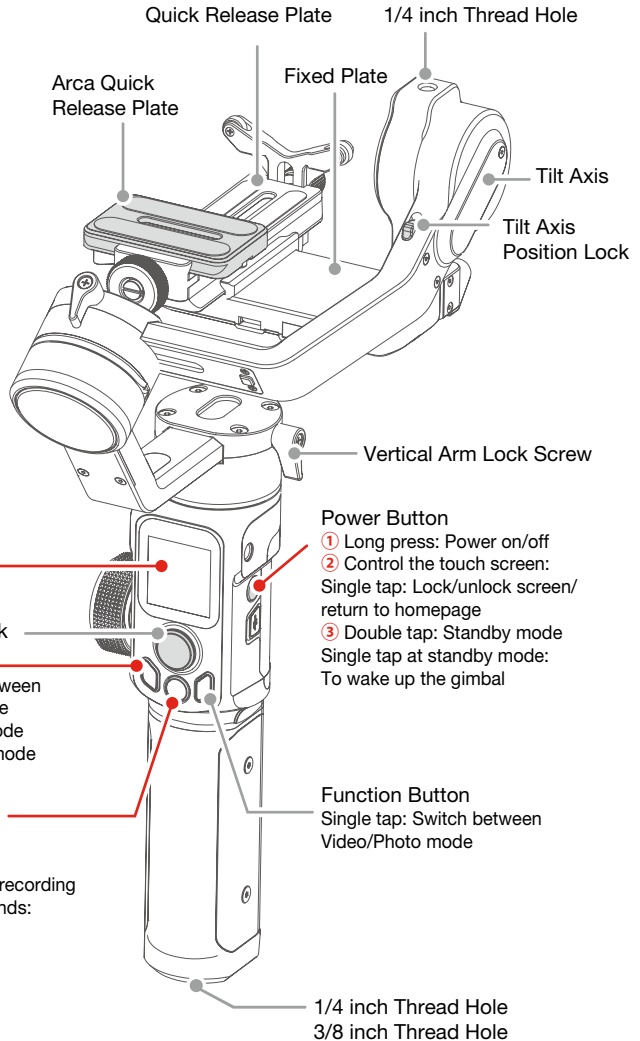

- Power Button**
- ① Long press: Power on/off
- ② Control the touch screen:
Single tap: Lock/unlock screen/
return to homepage
- ③ Double tap: Standby mode
Single tap at standby mode:
To wake up the gimbal

- Joystick**
- Mode Button**
Single tap: Switch between
pan mode & lock mode
Double tap: Follow mode
Triple tap: All Follow mode
- Shutter Button**
Press Halfway: Focus
Single tap:
Photo shooting/video recording
Long press for 5 seconds:
Auto-burst shot
(Press again to quit)

- Function Button**
Single tap: Switch between
Video/Photo mode

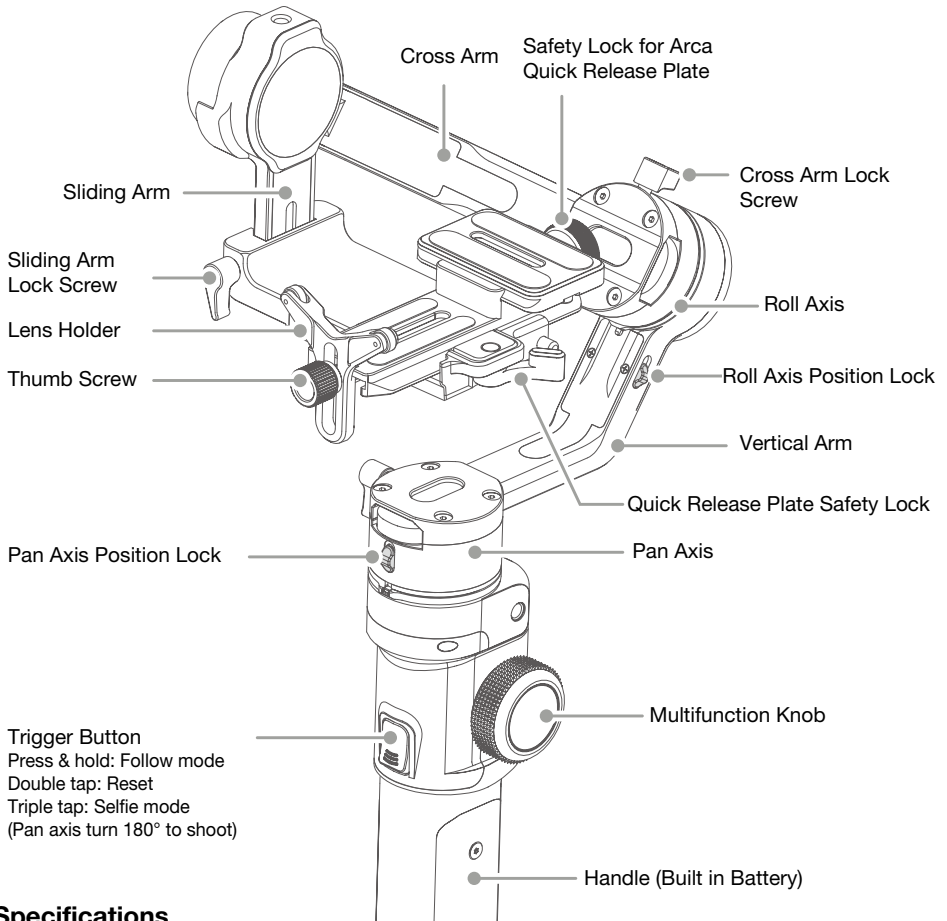

Specifications

Max. Tilting Range	230°	Theoretical Battery Life	14h (well-balanced)
Max. Rolling Range	360°	Weight	About 1100g
Max. Panning Range	360°	Payload Capability	2200g (well-balanced)
Tilt Follow Speed	2°/s ~ 75°/s	Compatible Cameras*	Canon, SONY, Panasonic and others.
Pan Follow Speed	3°/s ~ 150°/s		

This product does not include the camera.

Standard kit accessories



USB 2.0 to Micro
x1



USB 3.0 to Micro 3.0
x1



USB 2.0 to Mini
x1



USB 2.0 to Type C
x1



Type C to Multi
x1

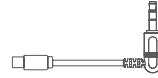

DC 2.5mm (Panasonic
Shutter Cable) x1



Anti-slip Metal Tripod
x1

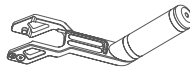

Versatile Arm
x1

2. Start to use

 Please read the detailed manual before you begin.

TIPS

- 1) Please mount the camera and balance it before Power ON.
- 2) When the battery is low, please charge the Gimbal.
- 3) When not in use for a long time, power off the Gimbal.
- 4) For quick start, utilising MVG220 basic features follow the steps below.

2.1 Charging

 Please fully charge the battery before power on the Gimbal for the first time.

Open the USB rubber cover. Connect the USB 2.0 to Type-C cable to charge. Quick charge is available.

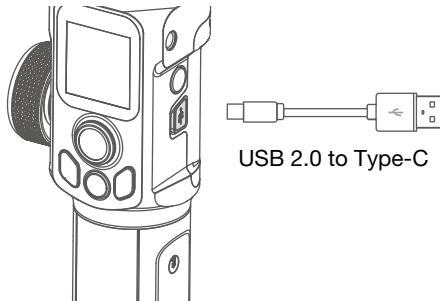

2.2 Position Lock

Each rotating axis has a position lock for convenient balancing and storage. Be sure to unlock the position locks before using the Gimbal.

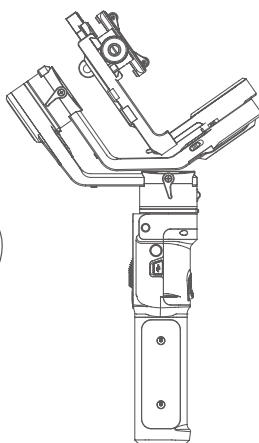
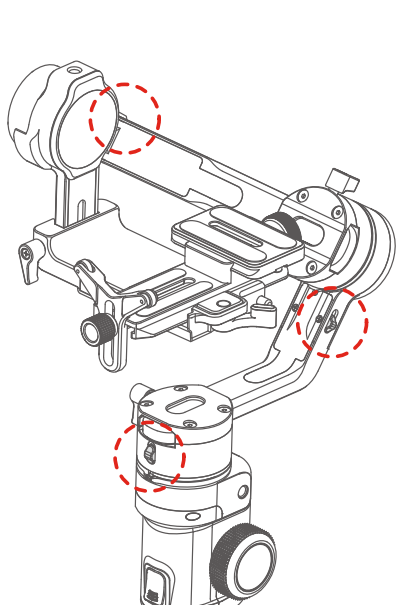

Stored lock status

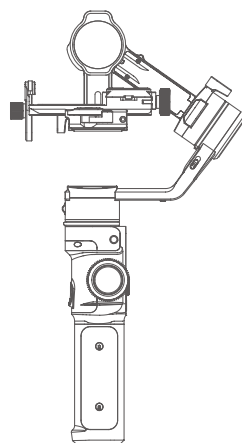

Balanced lock status



Download Manfrotto Gimbal app.



2.3 Camera Installation

 Make sure the battery and memory card are installed before camera installation.

Step 1: Mount quick release plate **①** on fixed plate **②**, lock it. Loosen the ARCA quick release plate safety lock **③**, take out ARCA quick release plate **④**.

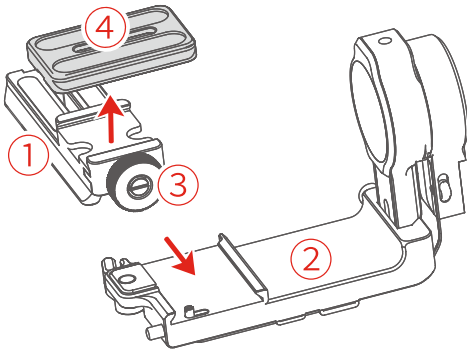

Step 2: Mount camera on ARCA quick release plate **④**.

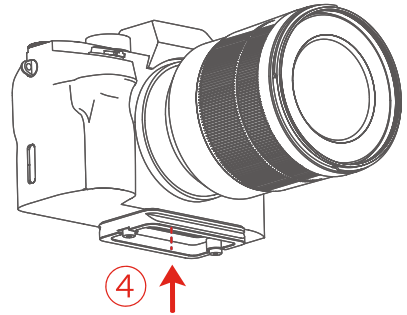

Step 3: Insert ARCA quick release plate directly into quick release plate **①**, tighten the safety lock **③** for ARCA quick release plate.

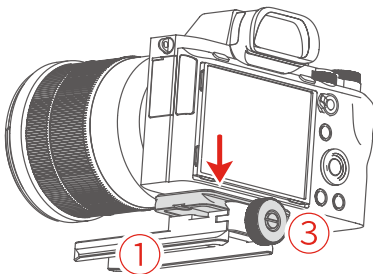

Step 4: Install lens holder **⑤** to support lens, and tighten the thumb screw.

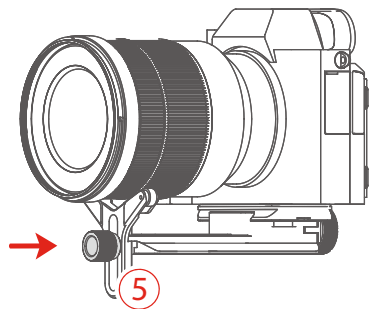

2.4 Gimbal Balancing

TIPS

- 1) Before balancing the Gimbal, please lock the Gimbal at the balanced lock status.
- 2) Lens cover should be removed from the camera and the memory card needs to be inserted to the camera to complete all the connections to ensure that the camera is ready for shooting.
- 3) When balancing the Gimbal, make sure the camera and Gimbal are all powered off.
- 4) If it is needed to add accessories after the balance is completed, Gimbal needs to be re-balanced again.

2.4.1 Balance Tilt Axis

- a. Unlock the tilt axis position lock ①, turn the camera lens upwards, and check the gravity center of camera.
- b. Loosen the sliding arm lock screw ②, slide the sliding arm ③ to balance the camera.
- c. Tighten the sliding arm lock screw ②, when the camera lens keeps upwards that means balanced.

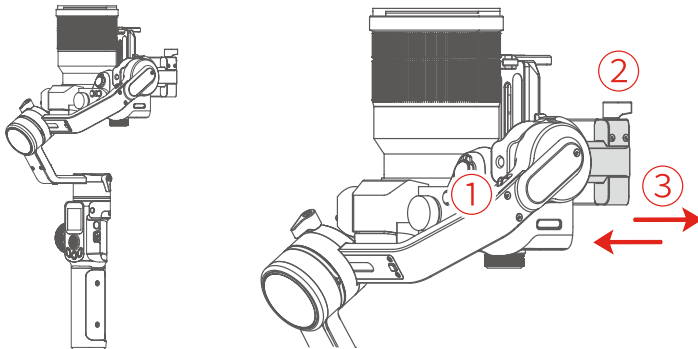

- (2) **a.** Place the camera lens forwards, check the gravity center of camera.
b. Unlock the quick release plate safety lock ①, adjust camera position until it can stay stable at any angles.
c. Lock the safety lock ①. Tilt the camera up or down, if it stays stable, it means balanced.

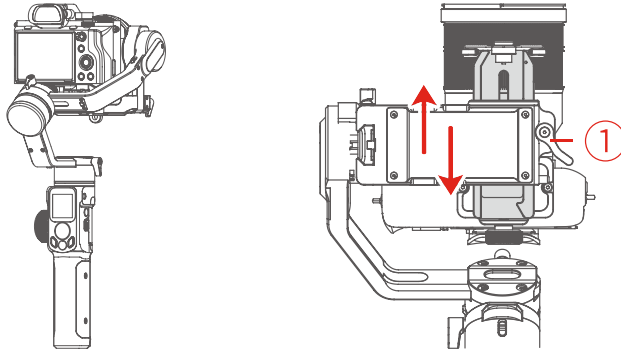

2.4.2 Balance Roll Axis

- a.** Tighten the tilt axis position lock ①, unlock the roll axis position lock ②, check gravity center of camera.
b. Loosen the cross arm lock screw ③, slide cross arm ④ to balance the camera position.
c. Tighten the cross arm lock screw ③, and tilt the camera to the left or right, if it stays stable, it means balanced.

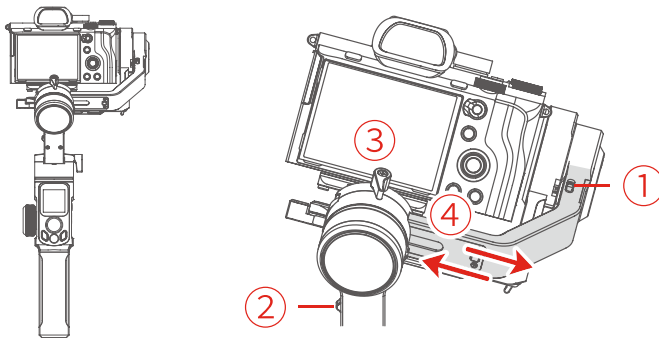

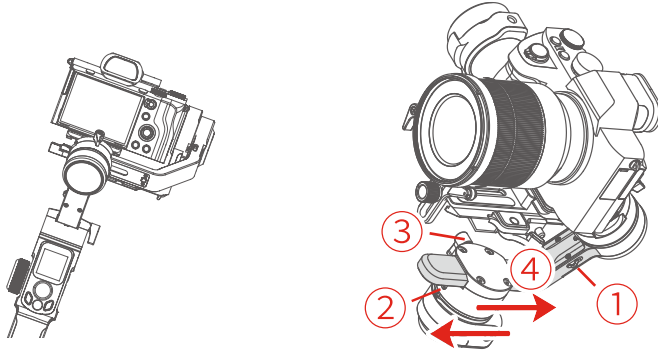

2.4.3 Balance Pan Axis

- a. Tighten the roll axis position lock ① after balanced tilt axis and roll axis. Unlock pan axis position lock ②, loosen vertical arm lock screw ③.
- b. Hold the handle angled to 15°~ 20°, check the camera's movement (roll axis will point down if not balanced).
- c. Slide vertical arm ④ to balance it until the camera stays there at any angles, balance succeeded.
- d. Tighten the vertical arm lock screw ③.



2.5 Power ON/OFF

 Be sure to unlock the position lock before using the Gimbal.

Long press power button, release the button until it shows  on display.

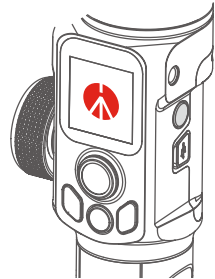

3. Function operation

3.1 Mode/Function Introduction

① Pan Mode (Default mode)

The roll and tilt direction are fixed, and the camera moves according to the left-right movements of the user's hand.

② Follow Mode

The roll direction is fixed, and the camera moves according to the left-right or up-down movements of the user's hand.

③ All follow Mode

The camera moves according to the user's hand.

④ Lock Mode

The orientation of the camera is fixed.

⑤ Reset

Return to Pan Mode, 3-axis return to initial position.

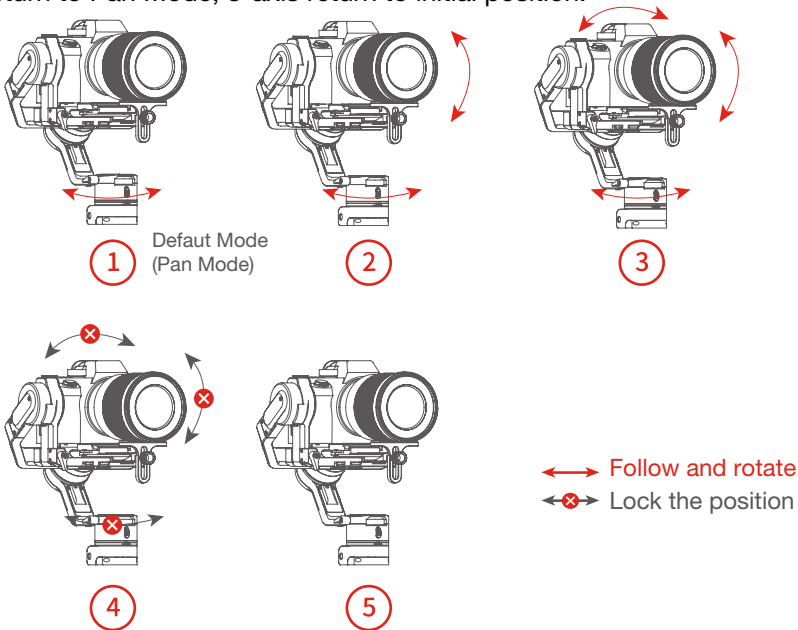

⑥ Manual Lock

Slide the tilt axis to a desired position, and hold on for 0.5 second. Set the camera position accurately and conveniently.

⑦ Auto-rotation mode

Auto-rotation mode helps user setup and automatically take time-lapse photography. It can set rotation route and time.

⑧ Inception Mode

Single tap **Inception** menu on screen, setting rotate speed and direction on the screen directly.

⑨ Selfie Mode

The camera turns 180° horizontally, selfie shooting is available.

⑩ Protrait Mode

Single tap Portrait menu on screen to enter portrait mode for livestream/Tiktok.

To get more videography skills with Gimbal and it's tutorial, please kindly visit our official or download Manfrotto Gimbal App.

<http://www.manfrotto.com>

3.2 Button Operation

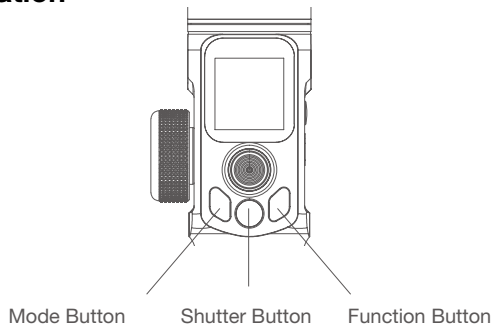

3.2.1 Mode operation

Button	Function	Description
Mode Button	Single tap	Pan/Lock mode (default mode)
	Double tap	Pan mode
	Triple tap	All follow mode

3.2.2 Shutter button

Button	Function	Description
Shutter Button (2stages-way press: half-way press & full- way press)	1. Focus	Single tap (half-way press)
	2. Photography	Full-way press after focusing.
	3. Video recording	Single tap (fully tap) start/stop
	4. Continuous shooting	Long press for 5 seconds, (fully press) ,after beep sound. Tap again to exit, default shoot 1 time every 5 seconds.

3.2.3 Function button operation

Button	Function	Description
Function Button	Photography/video recording	Single tap

3.2.4 Joystick

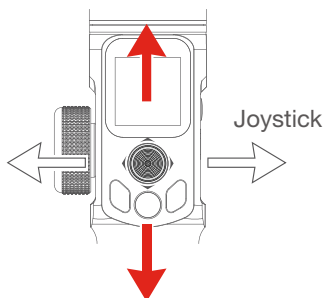

Button	Function	Description
Joystick	1. Camera lens move to upward, select the option above on display	Move to upward
	2. Camera lens move to downward, select the option below on display	Move to downward
	3. Camera lens move to left, select the option on the left on display	Move to left
	4. Camera lens move to right, select the option on the right on display	Move to right

3.2.5 Power button

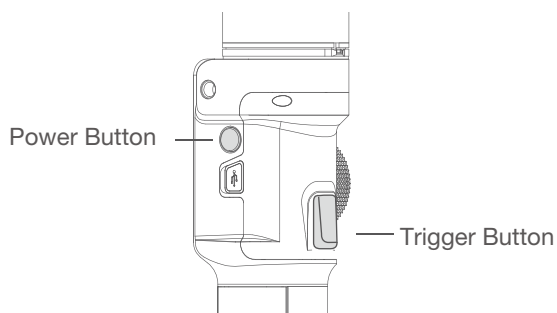

Button	Function	Description
Power Button	1. Power ON/OFF	Long press
	2. Lock/ unlock screen/ go back to home page	(Set up the display) Single tap
	3. Standby mode	Double tap
	4. Awaken the Gimbal	Single tap at standby mode

3.2.6 Trigger button

Button	Function	Description
Trigger Button	1. Follow mode	Press & hold
	2. Reset	Double tap
	3. Selfie shooting (Pan axis rotate 180° to shoot)	Triple tap

3.2.7 Multi-function knob

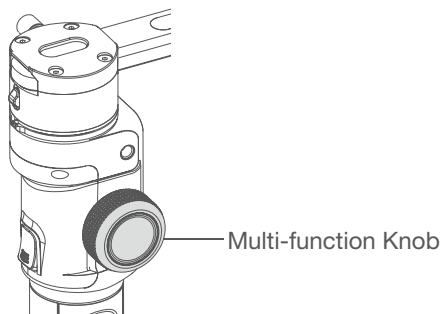

Button	Function	Description
Multi-function Knob	1. Control the current axis rotate direction	Rotate knob (default pan rotation mode)
	2. Switch between follow Focus/Zoom	Long press to switch
	3. Switch axis rotate among Tilt/Roll/Pan Axis	Single tap to switch (under the control of the axis direction mode)
	4. Switch between Follow Focus/Zoom	Single tap to switch (under the control of the follow focus or zoom mode)

3.3 USB Port

There are USB2.0 and Type C port at the fixed plate, which enable to connect to camera/follow focus and other devices.

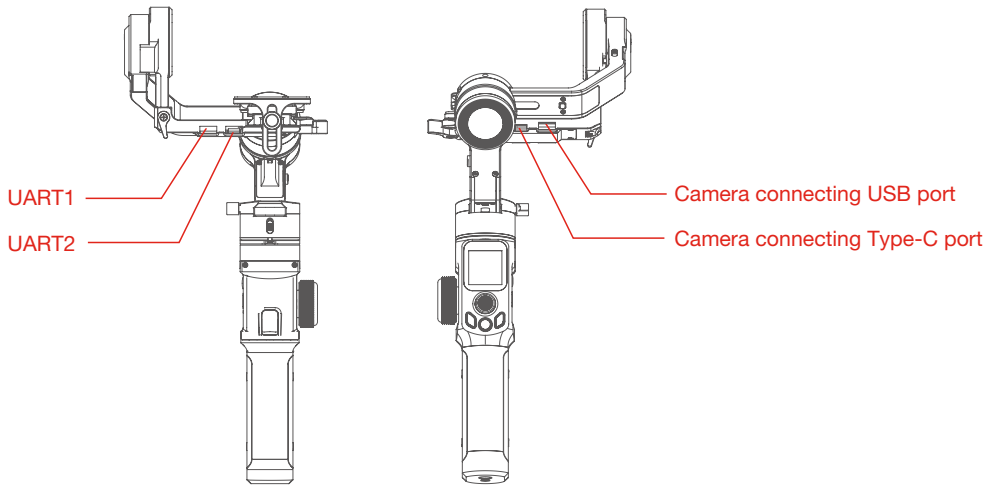

3.4 Touch Screen

3.4.1 Screen

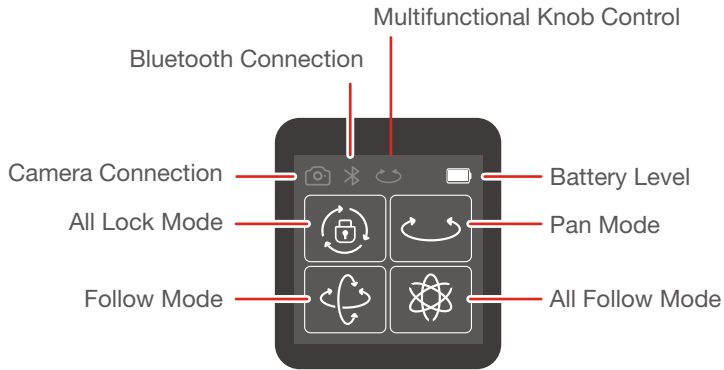

Icon	Mode	Icon	Mode
	Camera Connected/Photography		All Lock Mode
	Camera Unconnected		Pan Mode
	Video Recording Mode		Follow Mode
	Bluetooth Connected		All Follow Mode
	Bluetooth Unconnected		Tilt Axis Enabled
	Multi-function Knob Dnabled		Roll Axis Enabled
	Multi-function Knob Disabled		Pan Axis Enabled
	Zoom Status		Battery Level
	Follow Focus Status		

3.4.2 Display screen switch

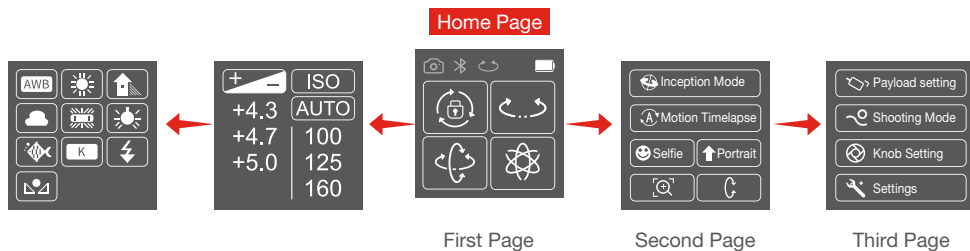

3.4.3 Usage of touch screen

Slide right to left: Flip to the right sub page.

Slide left to right: Flip to the left sub page/return to previous option.

Tap: Select current option.

3.4.4 Lock/unlock screen

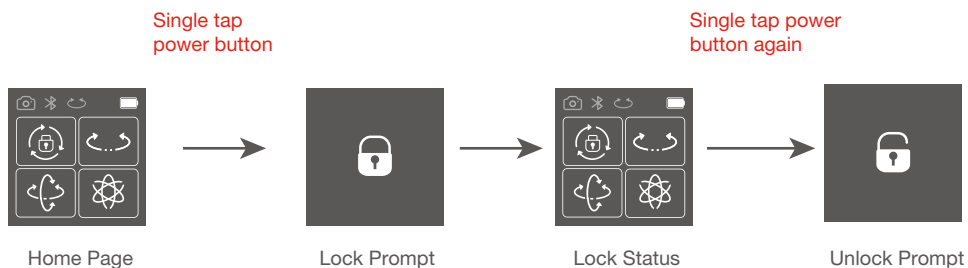

3.5 Modes Setting

Description:

← Slide right to left

→ Slide left to right

→ Tap to select current menu

3.5.1 Inception Mode setting

Single tap **Inception Mode** on screen, the camera lens will rotate to upward. Holding the Gimbal horizontally, and set rotation direction/speed/one circle or continuous circle. The camera will automatically rotate 360 degree to take inception footage with pre-set speed and direction after setup.

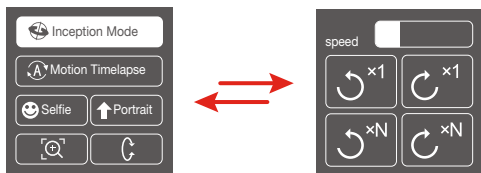

3.5.2 Motion-timelapse mode setting

Please refer to the **Motion Timelapse Mode** chapter.

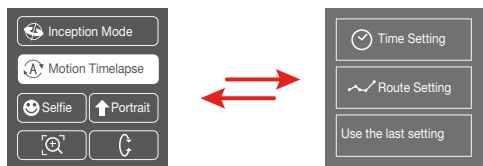

3.5.3 Protrait setting

Holding the Gimbal horizontally, tap **Portrait** on screen to enter protrait shooting.

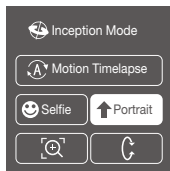

3.5.4 Other setting

Set motor power according to camera weight.

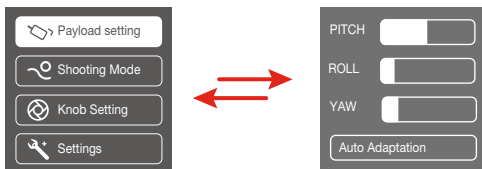

Set scene modes according to camera function.

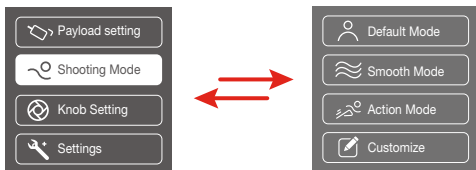

Higher sensitivity gives faster reaction of Gimbal/camera.

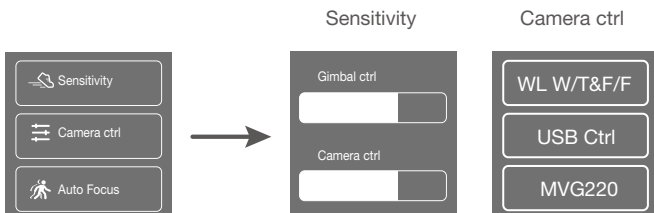
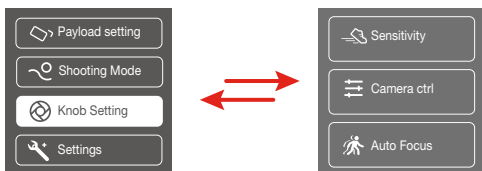

System setting

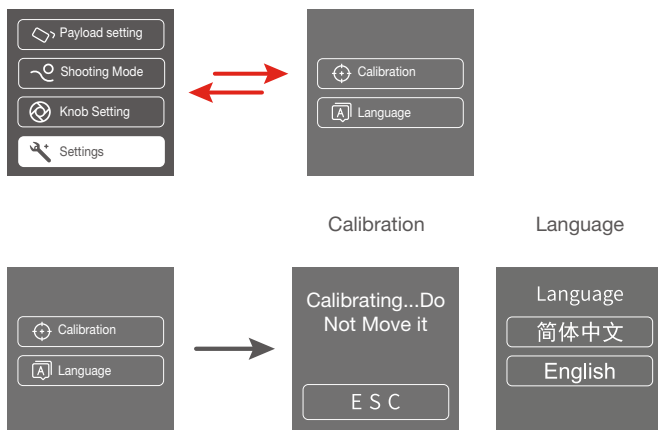

3.6 Motion-timelapse Mode

3.6.1 Motion-timelapse setting

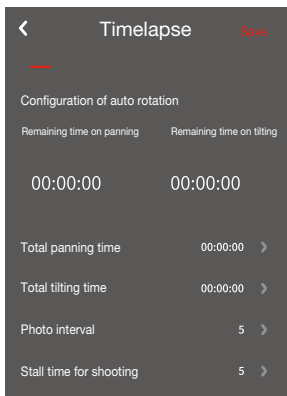

Method 1:

Set the Motion-timelapse mode parameters on Manfrotto Gimbal App. Enter the parameter setting interface to select the Motion-timelapse mode for setting. The maximum interval time is 59 seconds, while maximum staying time for long exposure photography is 58 seconds.



Note: The photographing interval setting must be longer than the stop time and less than the panning or the tilting rotation time.

Method 2:

Set the Motion-timelapse mode parameters by entering the Motion Timelapse interface on screen. Operate with joystick to set up time setting parameter on touch screen.

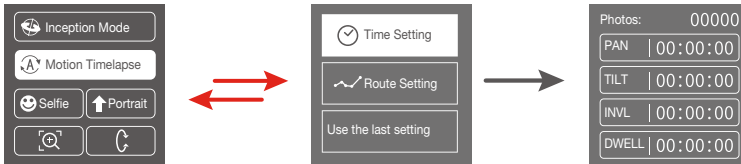

Display icon	Mode/Status	Minimum time setting	Maximum time setting
PAN (T1)	Pan axis rotation period	00:00:00	07:59:59
TILT (T2)	Tilt axis rotation period	00:00:00	07:59:59
INVL (t)	Photographic interval	00:00:00	00:00:59
DWELL (P)	Photography waiting time	00:00:00	00:00:58

PAN: Time required for the pan axis to rotate from the start point to the end point.

TILT: Time required for the tilt axis to rotate from the start point to the end point.

INVL: The time between the end of the previous shooting and the end of the next shooting.

DWELL: Gimbal staying time after sending a photographing command for long exposure.

* $T1/T2 > t > P$

3.6.2 Route setting

(1) Enter Route setting interface under Motion timelapse menu.

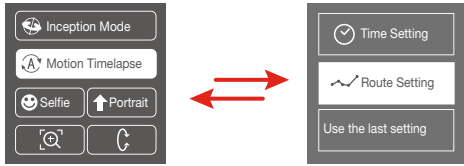

(2) Set the start position

Rotate the pan or tilt axis to a desired position, hold on for 0.5 seconds. Tap OK on screen to record a start position.

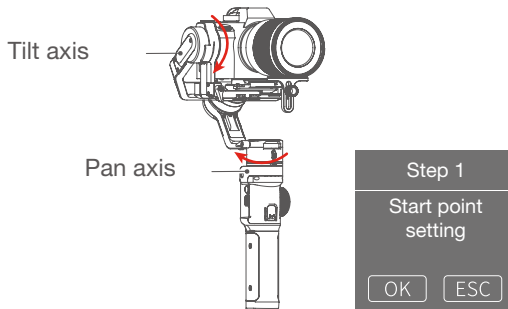

(3) Set the end position

Rotate the pan or tilt axis to a desired position, hold on for 0.5 seconds. Tap OK on screen to record an end position.

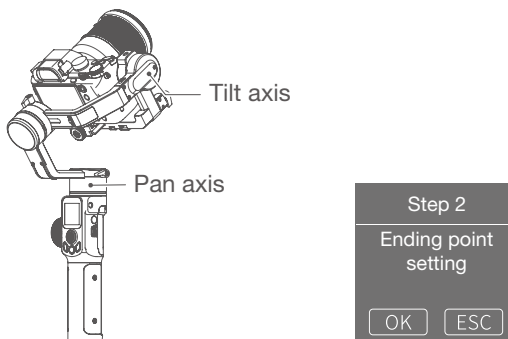

(4) Gimbal rotate automatically from the start position to the end position
Gimbal return the start initial position after setting, and then tilt and pan axis will start to rotate according to the parameter that has been set.

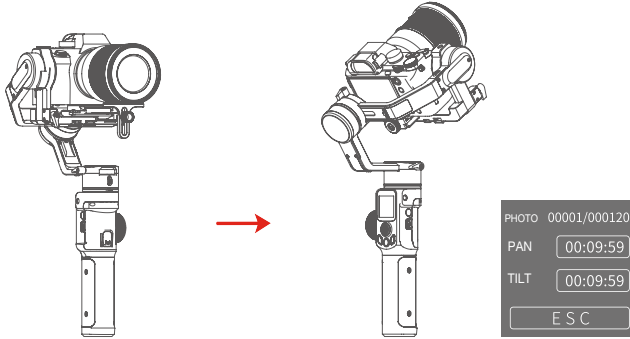

Exit



Double tap trigger button or the ESC icon on screen to exit



Exit motion timelapse mode and reset.

To get more videography skills with Gimbal and it's tutorial, please kindly visit our official or download Manfrotto Gimbal App.
<http://www.manfrotto.com>

3.7 Initialization

Initialization the Gimbal when:

- (1) The camera is not in balance.
- (2) Not use for a long period of time.
- (3) The surrounding temperature changes abruptly.

Steps:

- (1) Select Settings - Calibration on the display to enter the Gimbal initialization.

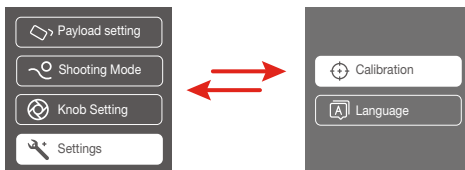

- (2) Place the Gimbal on the table, and the Gimbal automatically initializes. If the touch screen prompts that the calibration is successful, the initialization ends, otherwise the initialization fails.

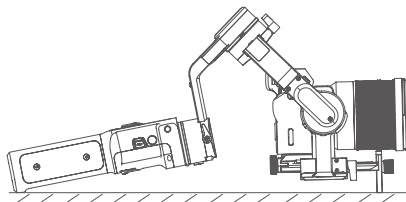

Calibrating...Do
Not Move it

ESC

(3) After the initialization is successful, slide the touch screen interface to the left/right or click the **ESC** on the screen to wake up.

Calibrating
completed

ESC

3.8 Manual Lock

Manually move camera to desired position, and hold for half a second. New tilt and/or pan positions are automatically saved.

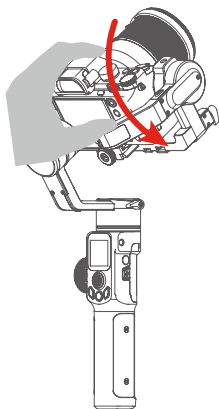

4. Manfrotto Gimbal App

4.1 Download Manfrotto Gimbal App



Download Manfrotto Gimbal
App.



4.2 App Connecting

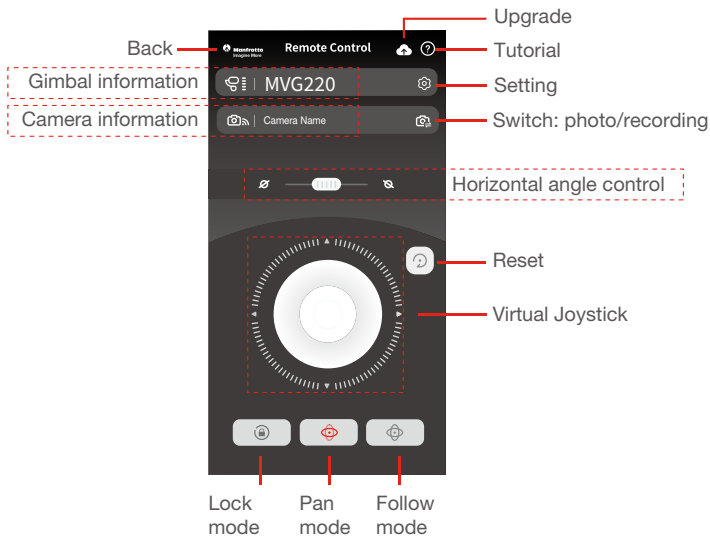

Steps:

- (1) Power on the Gimbal.
- (2) Select Wi-Fi connection menu on camera (find in setting-network-Wi-Fi), keep this page which has Wi-Fi name and its password on.
- (3) Login Manfrotto Gimbal App (or register).
- (4) The App will search around the enable devices. It will show **connect successful** the connection is done, if not, please exit and reconnect again.
- (5) Tap **connect to camera** on the App , select the right camera model in the list.
- (6) Select Wi-Fi name which get on step (2) in the camera model list on App, input the password. Most of the function can be achieved on App, such orient control/mode switch/parameter setting etc. If the connection failed, please confirm if the password is correct or exit and try to login Manfrotto Gimbal App again.

4.3 Firmware Upgrade

Upgrade firmware via App.

(1) Tap upgrade ICON  on App. (2) Select upgrade type. (3) Follow the prompts to upgrade the firmware.

Upgrade type introductions

Keyboard update	Repair/update or newly add button/touch screen/interaction functions, update more compatibility cameras which can be controlled through Wi-Fi.
Bluetooth firmware update	Repair/update or newly add Bluetooth functions, update more compatibility cameras, and etc.
Gimbal firmware update	Repair/update or newly add Gimbal control/function/parameter and etc.
LED icons update	Repair or update the icons in the screen.
USB Hub update	Repair/update or newly add control cameras/follow focus through USB cable, repair the bugs about camera control, and etc.



Noted: Gimbal has an update protection function. When the update fails, restart the Gimbal, it will return to the previous firmware. Connect the app and update again to resolve the problem. In addition, parts of the new functions require updating two or more firmware to take effect. It is recommended to update regularly to keep the firmware of the Gimbal as the latest version.



Please make sure disconnect Wi-Fi between camera and Gimbal if Wi-Fi connection is for controlling camera.

How to disconnect Wi-Fi connection of camera?

When Gimbal is on, slide touch screen to the left to find the settings. Press and hold trigger button, push up joystick, then click “Settings” to disconnect Wi-Fi connection.

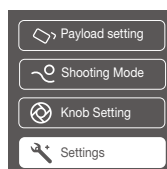

5. Accessories

5.1 Tripod

MVG220 is equipped with 1/4 inch thread hole and 3/8 inch thread hole to mount all type of Tripod for standing shooting.

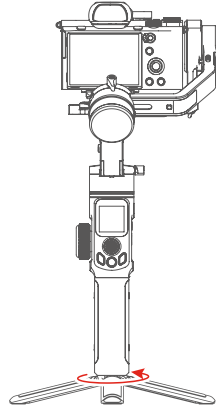

5.2 Versatile Arm

Installation: Install the versatile arm on the handle, align screw holes and tighten the screws by L shape wrench.(it is attached on versatile arm, the end cover of the versatile arm can be removed, and keeps 3 screws inside.)

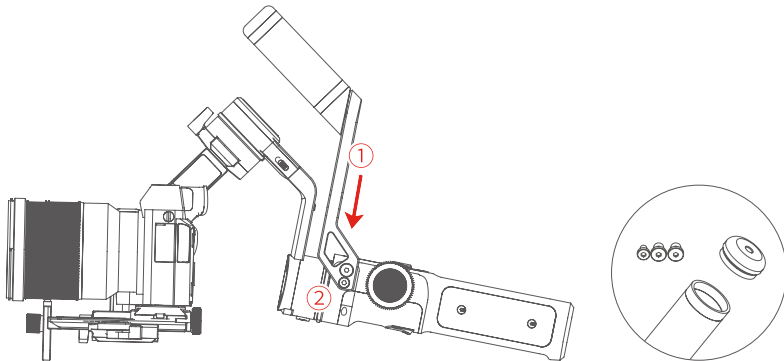

Disclaimer

Thanks for using Manfrotto product. The information in this document affects your safety and your legal rights and responsibilities. Read the entire document carefully to ensure proper configuration before use, Failure to read and follow instructions and warnings in this document may result in serious injury to yourself or others, or damage to your products or damage to other objects in the vicinity.

By using this product, you hereby signify that you have read this disclaimer and warning carefully and that you understand and agree to abide by the terms and conditions herein. You agree that you are solely responsible for your own conduct while using this product, and for any consequences thereof. You agree to use this product only for purposes that are proper and in accordance with all applicable laws, rules, and regulations, and all terms, precautions, practices, policies and guideline Manfrotto has made and may make available. Manfrotto accepts no liability for damage, injury or any legal responsibility incurred directly or indirectly from the use of product.

Manfrotto will not provide any service for any product obtained from abnormal channels.

Notice

1. Make sure motor spinning is not blocked by external force when the product is power on.
2. The product DO NOT contact water or other liquid if the product is not mark waterproof or splash-proof. Waterproof and splash-proof product DO NOT contact sea water or other corrosive liquid.
3. DO NOT disassembly the product except marked detachable. It need send to Manfrotto after-sales or authorized service center to fix it if you accidentally disassembly and cause abnormal work. The relevant costs are borne by user.
4. Prolonged continuous operation may cause the product surface temperature to rise, please operate carefully.
5. DO NOT drop or strike the product. If the product is abnormal, contact Manfrotto after-sales support.

Storage and Maintenance

1. Keep the product out of the reach of children and pets.
2. DO NOT leave the product near heat sources such as a furnace or heater. DO NOT leave the product inside of a vehicle on hot days.
3. Please storage the product in dry environment.
4. DO NOT overcharge or overuse the battery, otherwise it will cause damage to the battery core.
5. Never use the product when the temperature is too high or too low.

